

HAFCO WOODMASTER

OSCILLATING SPINDLE SANDER OPERATION MANUAL



**Model
OS-140**

Edition No : OS-001

Date of Issue : 11/2018

www.machineryhouse.com.au



OPERATION MANUAL

MACHINE DETAILS

MACHINE	OSCILLATING SPINDLE SANDER
MODEL NO.	OS-140
SERIAL NO.	
DATE OF MANF.	

DISTRIBUTED BY



www.machineryhouse.com.au

www.machineryhouse.co.nz

NOTE:

This manual is only for your reference. Owing to the continuous improvement of the HAFCO machines, changes may be made at any time without obligation or notice. Please ensure the local voltage is the same as listed on the specification plate before operating this electric machine.



NOTE:

In order to see the type and model of the machine, please see the specification plate. Usually found on the back of the machine. See example (Fig.1)

HAFCO
PRODUCT SPECIFICATION

MODEL:

CAPACITY:

SER. NO:

MFG DATE:

WEIGHT:

VOLTS:

MOTOR Kw:

www.machineryhouse.com.au
Made in China

FIG.1



OPERATION MANUAL

CONTENTS:

1. GENERAL MACHINE INFORMATION	
1.1. SPECIFICATIONS.....	4
1.2 CONTENTS OF PACKAGING.....	4
1.3 IDENTIFICATION.....	5
2. IMPORTANT INFORMATION	
2.1 GENERAL MACHINERY SAFETY	6
2.2 ADDITIONAL SAFETY FOR OSCILLATING SPINDLE SANDERS.....	8
3. SETUP	
3.1 UNPACKING AND CLEAN-UP.....	9
3.2 ATTACHING THE RUBBER FEET.....	9
3.3 POSITIONING THE SANDER.....	9
3.4 ELECTRICAL REQUIREMENTS.....	10
3.5 FULL-LOAD CURRENT RATING.....	10
3.6 INSTALLING SANDPAPER ONTO THE SPINDLES.....	10
3.7 INSTALLING AND REMOVING THE SPINDLE.....	11
3.8 INSTALLING THE TABLE INSERT.....	12
3.9 ALIGNING THE TABLE AT 90° TO THE SPINDLE.....	12
4. OPERATION	
4.1 TILTING THE TABLE.....	13
4.2 ON/OFF SWITCH.....	14
4.3 USING THE OSCILLATING SPINDLE SANDER.....	14
4.4 USING THE SANDER AT ANGLES 0° - 45°.....	15
5. MAINTENANCE	
5.1 MAINTENANCE REQUIRED FREQUENCY.....	16
5.2 TROUBLESHOOTING.....	16
5.3 OPTIONAL ACCESSORIES.....	17
SPARE PARTS SECTION.....	17
RISK ASSESSMENT.....	23

1.1 SPECIFICATION

Code	W792
MODEL	OS-140
Motor (kW)	0.37
Voltage	240V
Speed (RPM)	1425
Table Size(mm)	370 x 370
Table Tilt (Degrees)	0° - 45°
Spindle Length (mm)	115
Spindle Diameters (5 Included)	1/2", 3/4", 1", 1-1/2", 2"
Maximum Spindle Diameter Allowed	3" (optional)
Spindle Oscillation (mm)	24
Oscillations Per Minute	26
Dust Outlet (mm)	50
Height Overall (mm)	596
Height (base to table) (mm)	485
Width (mm)	440
Depth (mm)	360
Base Size (LxW) (mm)	300 x 280
Net Weight (kgs)	33

1.2 CONTENTS OF PACKAGE.

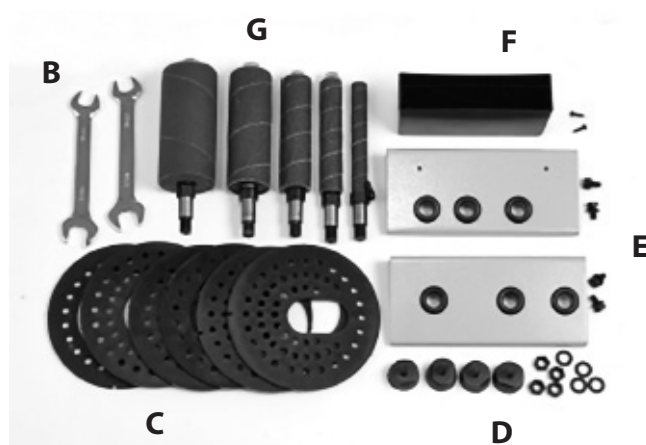
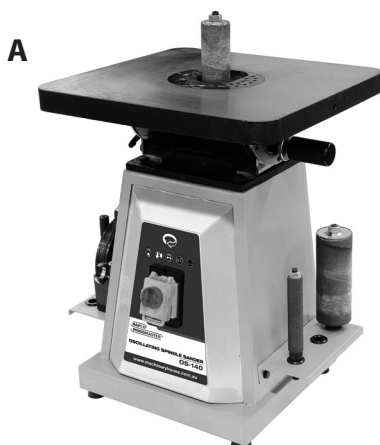

- A.** Oscillating Spindle Sander.
- B.** Spanners 14 & 17mm
- C.** Table Inserts(6)
- D.** Rubber Feet (4) & Hardware

- E.** Tool Holders for Drums (2) & Hardware
- F.** Holder for Table Inserts & Screws
- G.** Sanding Drums (5) - 1/2", 3/4", 1", 1-1/2", 2"

1.3 IDENTIFICATION

Become familiar with the names and locations of the controls and features shown below to better understand the instructions in this manual.

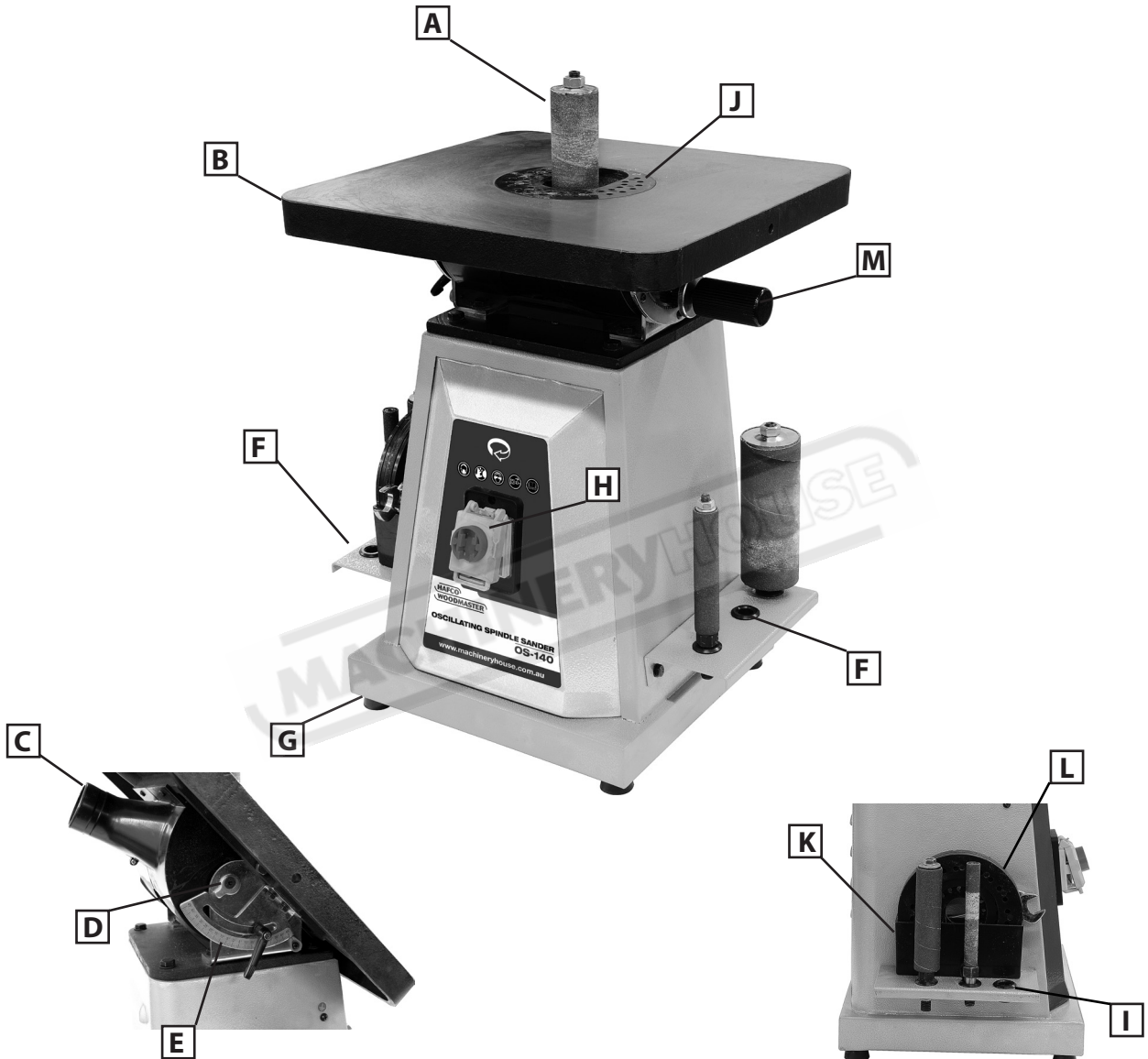

A	Spindle with Sanding Sleeve	H	ON / OFF Safety Switch
B	Work Table	I	Holder for Spindles
C	Dust Port	J	Table Insert (installed in table)
D	Cam for Table Leveling	K	Holder for Table Inserts
E	Table Angle Scale and Locking Handle	L	Table Inserts
F	Holder for Spindles	M	Geared Handle with Lock for Tilting Table

OPERATION MANUAL

2. IMPORTANT INFORMATION
2.1 GENERAL MACHINERY SAFETY

DO NOT use this machine unless you have read this manual or have been instructed in the use of this machine in its safe use and operation



WARNING

This manual provides safety instructions on the proper setup, operation, maintenance, and service of this machine. Save this manual, refer to it often, and use it to instruct other operators. Failure to read, understand and follow the instructions in this manual may result in fire or serious personal injury—including amputation, electrocution, or death.

The owner of this machine is solely responsible for its safe use. This responsibility includes, but is not limited to proper installation in a safe environment, personnel training and authorization to use, proper inspection and maintenance, manual availability and comprehension, of the application of the safety devices, integrity, and the use of personal protective equipment.

The manufacturer will not be held liable for injury or property damage from negligence, improper training, machine modifications or misuse.



Safety glasses must be worn at all times in work areas. Earmuffs should be worn if the work area is noisy.



Sturdy footwear must be worn at all times in work areas.



Gloves should NOT be worn when using this machine



Long and loose hair must be contained with a net or under a hat

OWNER'S MANUAL. Read and understand this owner's manual before using the machine.

DISCONNECT POWER FIRST. If using power, always disconnect the machine from power supply before making adjustments, or servicing the machine. This prevents any risk of injury from unintended startup or contact with live electrical equipment

TRAINED OPERATORS ONLY. Operators that have not been trained have a higher risk of being seriously injured. Only allow trained or supervised people to use this machine. When the machine is not being used, disconnect the power, to the machine to prevent unauthorized use—especially around children. Make the workshop safe.

2.1 GENERAL MACHINERY SAFETY Cont.

WEARING PROPER APPAREL Do not wear clothing, apparel or jewelry that can become entangled in moving parts. Always tie back or cover long hair. Wear non-slip footwear to avoid accidental slips, which could cause loss of operating control.

HEARING PROTECTION. Always wear hearing protection when operating or observing loud machinery. Extended exposure to this noise without hearing protection can cause permanent hearing loss.

REMOVE ADJUSTING TOOLS. Tools left on machinery can become dangerous projectiles upon startup. Never leave hex keys, wrenches, or any other tools on machine. Always verify removal before starting!

USE CORRECT TOOL FOR THE JOB. Only use this tool for its intended purpose. Do not force the machine or its attachments to do a job for which they were not designed. Never make unapproved modifications. Modifying the machine or using it differently than intended may result in malfunction or mechanical failure that can lead to personal injury or death!

AWKWARD POSITIONS. Keep proper footing and balance at all times when operating machine. Do not overreach! Avoid awkward hand positions that make operating control difficult. This could increase the risk of accidental injury

GUARDS & COVERS. Guards and covers reduce accidental contact with moving parts or flying debris. Make sure they are properly installed, undamaged, and working correctly.

FORCING MACHINERY. Do not force the machine. It will do the job safer and better at the rate for which it was designed.

NEVER STAND ON MACHINE. Serious injury may occur if the machine is tipped or if the cutting tool is unintentionally contacted

STABLE MACHINE. Unexpected movement during operation greatly increases risk of injury or loss of control. Before starting, verify machine is stable and if using a mobile base it is locked in position.

UNATTENDED OPERATION. To reduce the risk of accidental injury, turn the machine OFF and ensure all moving parts have completely stopped before walking away. Never leave the machine running while unattended.

MAINTAIN WITH CARE. Follow all maintenance instructions and lubrication schedules to keep the machine in good working condition. A machine that is improperly maintained could malfunction, leading to serious personal injury or death.

CHECK DAMAGED PARTS. Regularly inspect the machine for any condition that may affect the safe operation. Immediately repair or replace damaged or parts that are incorrectly fitted before operating.

CHILDREN & BYSTANDERS. Keep children and bystanders at a safe distance from the work area. Stop using machine if they become a distraction.

OPERATION MANUAL

2.2 ADDITIONAL SAFETY FOR OSCILLATING SPINDLE SANDERS

DO NOT use this machine unless you have read the manual or have been trained and assessed to a competent level in its safe use and operation.



Safety glasses must be worn when operating this equipment



Long and loose hair must be contained when operating this equipment.



Safety footwear must be worn when operating this equipment



Close fitting/protective clothing must be worn when operating the sander.



Dust mask must be worn when operating this equipment.



Hearing protection must be used when operating this equipment.

PRE-OPERATIONAL SAFETY CHECKS

1. Ensure that risk assessment has been read.
2. Ensure no slip/trip hazards are present in workspaces and walkways.
3. Be familiar with the operation of the ON/OFF starter and lockable E-Stop.
4. Be aware of other people in the nearby area and ensure that it is clear before starting.
5. Check that the stand is level and adjust as required.
6. Check that the table has the correct insert ring.
7. Start the dust extraction unit before using the Oscillating Spindle Sander.
8. Faulty equipment must not be used. Immediately report suspect machinery.

OPERATIONAL SAFETY CHECKS

1. Never leave the machine running unattended.
2. Check sanding sleeves for wear, tear, cracks and flaws. Discard faulty sleeves.
3. Ensure the material to be sanded can be held safely during the operation.
4. Use a safe working posture (beware of entanglement).
5. Machine only stock which rests securely on the table.
6. Slowly move the work piece across the face of the spindle in a uniform manner.
7. Apply firm and even pressure without forcing material into the sanding sleeve.
8. Keep hands in sight and clear of all moving parts.
9. Never overreach — you may slip and fall into the machine.
10. Before making adjustments switch off the Oscillating Spindle Sander, bring the machine to a complete stand still and isolate the machine.
11. Report any worn sanding sleeves immediately for replacement.

HOUSEKEEPING

1. Switch off the equipment, engage E-stop and reset all guards to a fully closed position.
2. Return all tooling and fixtures to the correct storage location.
3. Leave the machine and work area in a safe, clean and tidy state.
4. Dispose of waste material in an appropriate recycling or waste bin

POTENTIAL HAZARDS

- Eye injuries
- Moving object kickback
- Inhalation of dust particles
- Contact with rotating sanding sleeve

DON'T

- Attempt to sand very small items
- Removal or modification of safety devices
- Distracting operator
- Sand metal
- Wear gloves when operating this machine

OPERATION MANUAL

3. SETUP

3.1 UNPACKING AND CLEAN-UP

1. Carefully remove all contents from the shipping carton. Compare the contents with those listed on Page 4. Make sure that all of the items are accounted for, before discarding any packing material. Place parts on a protected surface for easy identification and assembly. If any parts are missing or broken, please contact your distributor for replacements. **DO NOT** turn your machine **ON** if any of these items are missing. You may cause personal injury or damage to the machine.
2. Report any shipping damage to your local distributor.
3. Clean all rust protected surfaces with ordinary house hold type grease or spot remover. Do not use; gasoline, paint thinner, mineral spirits, etc. These may damage painted surfaces.
4. Apply a coat of paste wax to the table to prevent rust. Wipe all parts thoroughly with a clean dry cloth.
5. Set packing material and shipping carton aside. Do not discard until the machine has been set up and is running properly.

3.2 ATTACHING THE RUBBER FEET

1. **DISCONNECT THE MACHINE FROM THE POWER**
2. Lower the machine onto its side to access the four holes in the bottom corners of the base.
3. Insert the threaded portion of the rubber foot through the machine's base, and put on a washer, followed by a nut to secure the foot in place. (Fig.3.1)
4. Install the remaining three rubber feet and then raise the machine to its operating position. The rubber feet will prevent the machine from slipping on the bench during use, and reduce any vibration from the sanding operation.



FIG.3.1

3.3 POSITIONING THE OSCILLATING SPINDLE SANDER.

When selecting the position for the machine, consider the largest size of workpiece that will be processed on the machine and provide enough space around the machine for operating the machine safely. Consideration should be given to the installation of auxiliary equipment, and room for any maintenance that may need to be carried out. The Oscillating Spindle Sander must be positioned where it is to be used on a sturdy workbench, at a suitable, safe height for the sanding operations to be carried out.

WARNING

THE MACHINE MUST HAVE THE POWER PLUG REMOVED FROM THE SOCKET BEFORE ANY ADJUSTMENTS ARE ATTEMPTED AND REMAIN UNPLUGGED UNTIL COMPLETED.

OPERATION MANUAL

3.4 ELECTRICAL REQUIREMENTS.

Place the machine near an existing power source. Make sure all power cords are protected from traffic, material handling, moisture, chemicals, or other hazards. Make sure there is access to a means of disconnecting the power source. The electrical circuit must meet the requirements for 240V, 50 Hz.

NOTE : The use of an extension cord is not recommended as it may decrease the life of electrical components on your machine.

NOMINAL VOLTAGE.....	240V
CYCLE.....	50 Hz
PHASE.....	SINGLE PHASE
POWER SUPPLY CIRCUIT.....	10 AMPS
FULL LOAD CURRENT.....	1.6 AMPS

3.5 FULL-LOAD CURRENT RATING

The full-load current rating is the amperage a machine draws at when running at 100% of the output power. Full-Load Current Rating for this machine at 240V is 1.6 Amps

It should be noted that the full-load current is not the maximum amount of amps that the machine will draw. If the machine is overloaded, it will draw additional amps beyond the full-load rating and if the machine is overloaded for a long period of time, damage, overheating, or fire may be caused to the motor and circuitry.

This is especially true if connected to an undersized circuit or a long extension lead. To reduce the risk of these hazards, avoid overloading the machine during operation and make sure it is connected to a power supply circuit that meets the requirements.

3.6 INSTALLING SANDPAPER ONTO THE SPINDLES

The Oscillating Spindle Sander is supplied with 5 rubber cylinder Spindles, 1/2", 3/4", 1", 1-1/2" and 2" diameters, that will hold sandpaper sleeves of various grits.

The Spindle consists of a rubber body with a metal axle passing through the centre (Fig3.2). The axle has a key which locates into a key way in the rubber body. Normally these should need not be disturbed unless the rubber body is damaged.

At either end of the body are two large compression washers. At the top is a nut and washer to secure the cylindrical sandpaper. The low part of the axle is threaded, which locates into the motor drive.



FIG.3.2

3.6 INSTALLING SANDPAPER ONTO THE SPINDLES Cont.

1. To remove a sandpaper sleeve from a spindle, take off the top nut with a wrench, remove the washer, and slide the sanding sleeve off of the rubber spindle. (Fig.3.3)

NOTE: If removal is difficult sprinkle a small amount of talcum powder onto the rubber to aid fitting the new sandpaper sleeve.

2. To install a new sandpaper sleeve onto a spindle, slide the sleeve onto the rubber body so that it fits centrally with no edge overhanging.
3. Replace the washer and top nut. Tighten the nut to expand the rubber body. This will grip the sanding drum. Fig.3.3)

NOTE: Do not over-tighten as this will distort the rubber body.

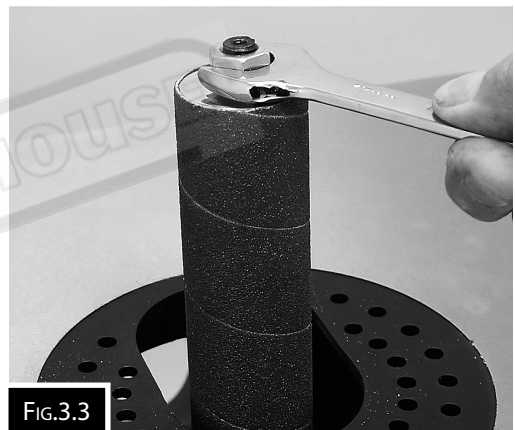

FIG.3.3

3.7 INSTALLING AND REMOVING THE SPINDLE

1. DISCONNECT THE MACHINE FROM THE POWER
2. For easy access tilt the table to 45° and remove the table insert.
3. Lower the spindle down through the table's center hole, and insert the spindle's threaded end into the open end of the motor drive spindle.
4. Turn the sanding spindle counter-clockwise with your hand to thread and install the sanding spindle into the motor drive spindle.
5. With the two supplied open ended wrenches, tighten the spindle in place. With one wrench hold the motor drive spindle and with the other wrench tighten the sander spindle. Do not over-tighten. (Fig.3.4)

To remove a spindle,

1. DISCONNECT THE MACHINE FROM THE POWER.
2. Tilt the table to 45° and remove the table insert.
3. Reverse the process in Steps 4 & 5 as outlined above.



FIG.3.4

NOTE: Tilting the table to 45° is only to gain access easily.

HAFCO WOODMASTER

OPERATION MANUAL

3.8 INSTALLING THE TABLE INSERT

The HAFCO WOODMASTER OS-140 Oscillating Spindle Sander comes with a variety of table Inserts, each with a different center hole diameter to be used with the matching spindle size. (Fig.3.5)

NOTE: ALWAYS use a table insert when sanding. Failure to do so may cause serious injury to the operator or damage to the machine.

There are two styles of table inserts supplied with the machine.

One style has a round center hole for sanding with the table in the 90° position. The second style insert has an oval center hole for use when the table is tilted at an angle for sanding. This oval hole protects the insert from being damaged during the sanding operation. To install an insert into the table, notice the cutout on the edge of the insert. This aligns with the peg in the recess on the table (Fig.3.6). Lower the insert into position, making sure that the insert locates in the recess and is flush with the table.

To remove a table insert, disconnect the machine from the power supply and simply push it out of the table with your finger from underneath.

3.9 ALIGNING THE TABLE AT 90° TO THE SPINDLE

The table has the ability to tilt between 90° to 45°, (0° to -45°). The table angle has been set in the factory, but before the sander is used for the first time, squaring the table to the spindle needs to be checked.

To align the table

1. DISCONNECT THE MACHINE FROM THE POWER
2. Loosen the table locking handle (Fig.3.7)
3. Rotate the geared handle on the opposite side of the tilt mechanism and move the table into the 90-degree position. (Fig.3.8)
4. Lightly tighten the table in place so that any tilting adjustments can be made.



FIG.3.5

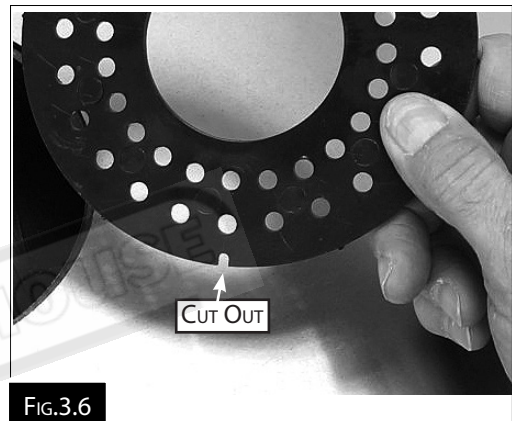

FIG.3.6

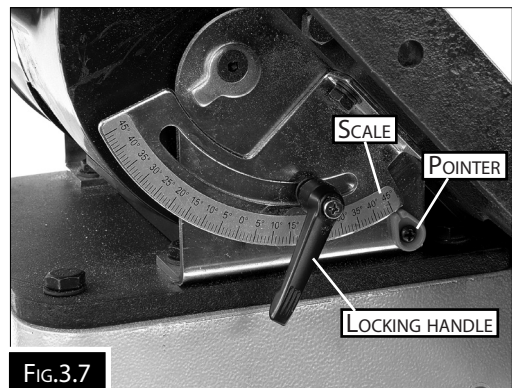

FIG.3.7



FIG.3.8

5. Using a 90° square placed on the table top, move the square to the spindle. It should measure 90°. (Fig.3.9). If the table is not square to the spindle, an adjustment can be made to the table setting.
6. Located under the work table are two stop cams, one on either side of the table brackets, which can be adjusted to level the table (Fig.3.10). With a 4mm hex wrench, loosen the cam's centre screw to rotate the cams to raise or lower the table setting. When the table to spindle angle is at 90°, tighten the hex screw to lock the stop cams in position.
7. With the table stops set then check the pointer on the table angle scale. The pointer should point to 0°. If the pointer is not on the zero then with a Phillips screwdriver, loosen the screw in the centre of the pointer and align the pointer with the 0° position on the scale, and then re-tighten screw. (Fig.3.10)

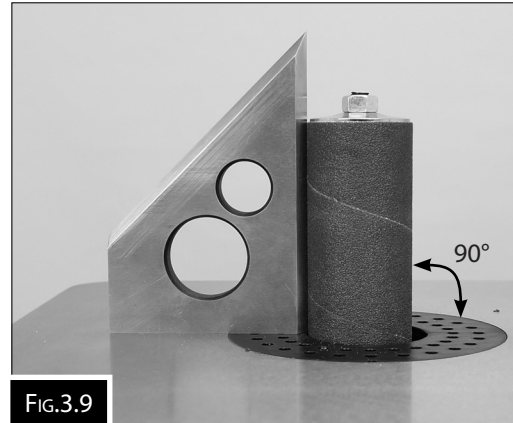

FIG.3.9

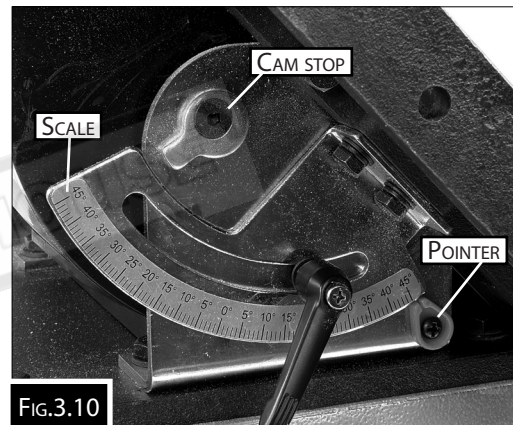

FIG.3.10

4. OPERATION

4.1 TILTING THE TABLE

NOTE: Before tilting the table, remove the table insert with the round cutout as the spindle will touch the insert and may break it.

1. Loosen the side lever handle and ring so that the table can be tilted.
2. The table will tilt 0° - 45°. Using the angle scale on the left side of the machine, tilt the table so that the pointer lines up against the required angle on the scale.
3. Once the desired table angle has been reached, tighten the locking handle and ring.
4. Locate the table insert with the oval cutout and place it into the table top. (Fig.4.1)



FIG.4.1

4.2 ON/OFF SWITCH

The ON/OFF safety switch is located on the front of the machine for quick, easy and safe access. The switch is fitted with a yellow door with a RED button in the centre of it.

To start the machine the yellow door needs to be released by pressing against the catch (Fig.4.1) to open it and reveal the green ON and RED stop buttons. Push the bottom green button (A) to turn the machine ON. Push the top red button (B) to turn the machine OFF. (Fig.4.2)

In an emergency the red button on the yellow door can be pressed and held with the catch and the machine will stop. With the door closed the machine cannot be started until the catch is released and the buttons exposed.

CAUTION: Never walk away from the machine while it is still running. Always lock the switch in the Off position and unplug from the power supply when not in use.

4.3 USING THE OSCILLATING SPINDLE SANDER

1. Connect the machine to the power
2. Start the machine and wait until the motor has build up to full speed. The OS-140 Oscillating Spindle Sander features a spindle that automatically oscillates (moves up and down) 24mm. This movement ensures that the spindle's sandpaper gets maximum sanding use along the sleeve, and does not wear in just one area.

CAUTION NEVER START THE MACHINE WITH WORK IN CONTACT WITH THE SPINDLE

3. Looking from the front of the machine, the motor turns in a clockwise direction. Always feed the work across the spindle, against the direction of the spindle rotation. (Fig.4.3)
4. NEVER feed the work into the machine and stand with your body directly behind it. The machine could force the work into the operator and cause serious injury.

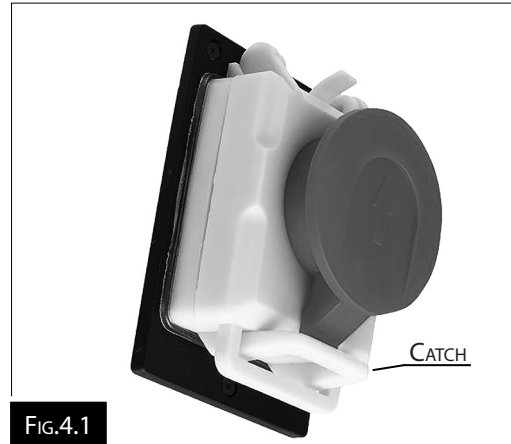

FIG.4.1

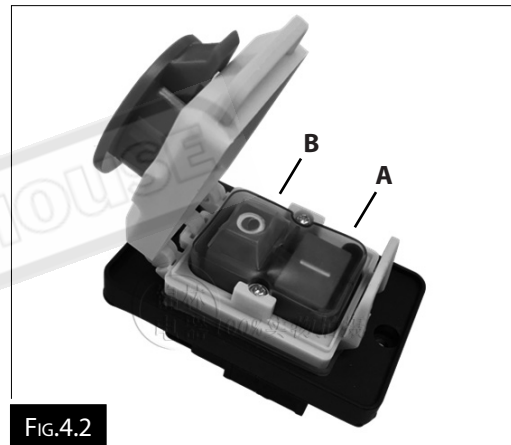

FIG.4.2

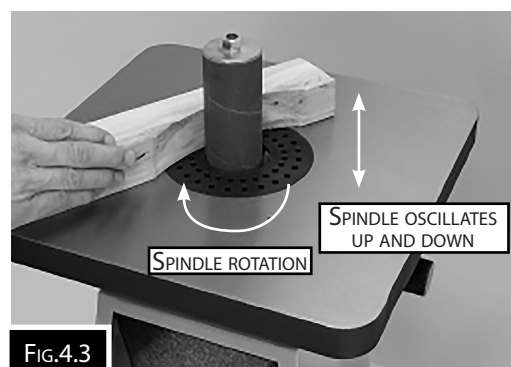

FIG.4.3

4.4 USING THE SANDER AT ANGLES 0° - 45°

1. DISCONNECT THE MACHINE FROM THE POWER
2. Take out the round insert and store carefully. Put in the oval insert. Slacken the table securing knobs either side of the machine.
3. Tilt the table to the desired angle and re-tighten the locking knobs.
4. Feed the work into the machine always against the direction of rotation. (Fig.4.4)

NOTE: When the table is tilted to a particular angle, the same angle will only remain constant if the workpiece is sanded parallel to the spindle.

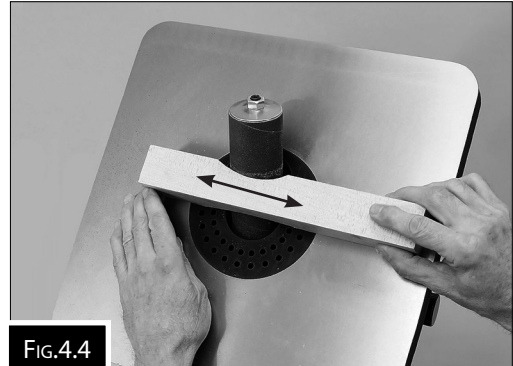

FIG.4.4

4.5 DUST EXTRACTION

This machine is fitted with a 50mm diameter dust extraction outlet. This is located at the rear of the machine directly under the table. (Fig.4.5)

Attach your shop's dust collector hose to this dust port to collect the dust produced while sanding.

NOTE: DO NOT operate the sander without a dust collector and wear a protective dust mask. Sanding creates substantial amounts of dust which can be harmful to your respiratory system!

Always start the dust collector before the machine is started. The holes in the table insert are used to extract the dust through the table.

Minimum requirement for dust extraction 200CFM

⚠ WARNING Some dust created by power sanding sawing, grinding, drilling, and other construction activities contains chemicals that may cause cancer and birth defects or other reproductive harm. Your risk from exposure to these chemicals varies, depending on how often you do this type of work. To reduce your exposure, work in a well-ventilated area and with approved safety equipment, such as dust masks that are specially designed to filter out microscopic particles.

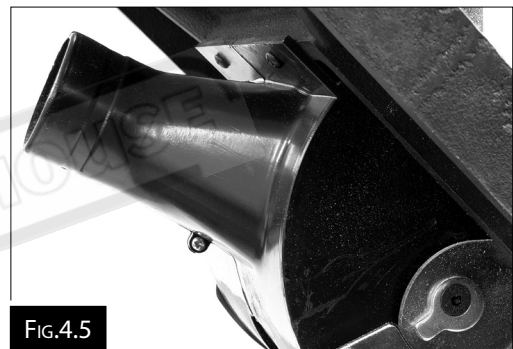

FIG.4.5

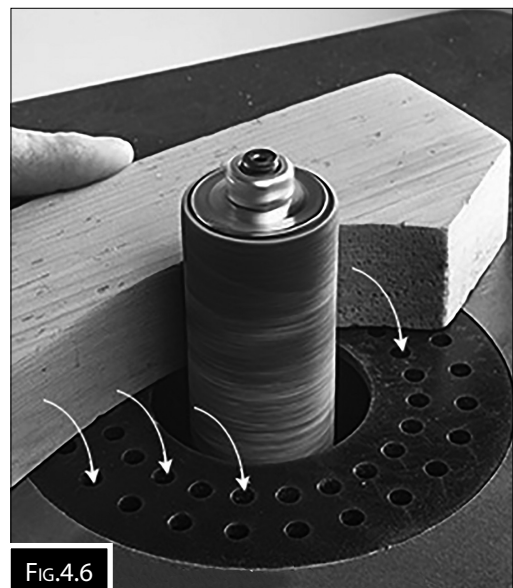

FIG.4.6

OPERATION MANUAL

5 MAINTENANCE

⚠ WARNING Turn the power switch "OFF" and disconnect the plug from the outlet prior to adjusting or maintaining the sander. DO NOT attempt to repair or maintain the electrical components of the motor. Take the sander to a qualified service technician for this type of maintenance.

5.1 MAINTENANCE REQUIRED FREQUENCY

- | | |
|---|------------------|
| 1. Check the power cord and plug for any damage. | Before each use. |
| 2. Check sanding spindles and sleeves for damage or wear. | Before each use. |
| 3. Check all guards and hardware to make sure they are secure. | Before each use. |
| 4. Check all moving parts for alignment and binding issues. | Before each use. |
| 5. Dress/Clean sanding surfaces for best abrasive action. | As needed |
| 6. Replace sanding sleeves when worn or damaged. | As needed. |
| 7. Clean and vacuum dust from the motor housing and other sander parts. | As needed. |
| 8. Keep iron tables free of rust. Apply coat of paste wax or silicon spray. | As needed. |

NOTE: Lubrication of the bearings is not necessary, as they are sealed and pre-lubricated for life. Just replace a bearing if failure occurs. Do not use compressed air near bearings. Simply wipe the exposed bearing surfaces with a dry cloth to clean them.

⚠ WARNING If blowing sawdust, wear proper eye protection to prevent debris from blowing into eyes

5.2 TROUBLESHOOTING

Problem	Possible Cause	Solution
Sander will not start	1. Sander unplugged from wall or motor 2. Fuse blown or circuit breaker tripped 3. Cord is damaged	1. Check all plug connections 2. Replace fuse or reset circuit breaker 3. Replace the cord
Sander does not come up to speed	1. Extension cord is too light or too long 2. Low current	1. Replace with adequate size and length of cord 2. Contact a qualified electrician
Machine vibrates excessively	1. Work table or base is on an uneven surface	1. Adjust the table or base so that it rests evenly 2. Bolt down the machine
Sanded edge is not square	1. Table not square to the spindle	1. Use a square to adjust the table to the spindle
Sanding marks on the wood	1. Workpiece is held still 2. Wrong grit of sanding sleeve 3. Feed pressure is too great 4. Sanding against the wood grain	1. Keep the workpiece moving 2. Use coarser grit for stock removal fine grit for finish sanding 3. Never force the workpiece 4. Sand with the grain

OPERATION MANUAL

5.3 OPTIONAL ACCESSORIES

HAFCO WOODMASTER has a range of sanding sleeves available for this machine. To arrange your order contact your local dealer with your order or purchase online at

www.machineryhouse.com.au

www.machineryhouse.co.nz

Code	Size	Grit
A8110	1/2"x115	80
A8112	1/2"x115	120
A8114	3/4"x115	80
A8116	3/4"x115	120
A8118	1" x 115	80
A8120	1" x 115	120
A8122	1-1/2"x 115	80
A8124	1-1/2"x 115	120
A8130	2" x 140	80
A8132	2" x 140	120

Sanding sleeves are supplied in a pack of 3

SPARE PARTS SECTION

The following section covers the spare parts diagrams and lists that were current at the time this manual was originally printed. Due to continuous improvements of the machine, changes may be made at any time without notification.

HOW TO ORDER SPARE PARTS

1. Have your machines **model number, serial number & date of manufacture** on hand, these can be found on the specification plate mounted on the machine
2. A scanned copy of your parts list/diagram with required spare part/s identified
3. Go to www.machineryhouse.com.au/contactus and fill out the enquiry form attaching a copy of scanned parts list.



OPERATION MANUAL

SPARE PARTS DIAGRAM A

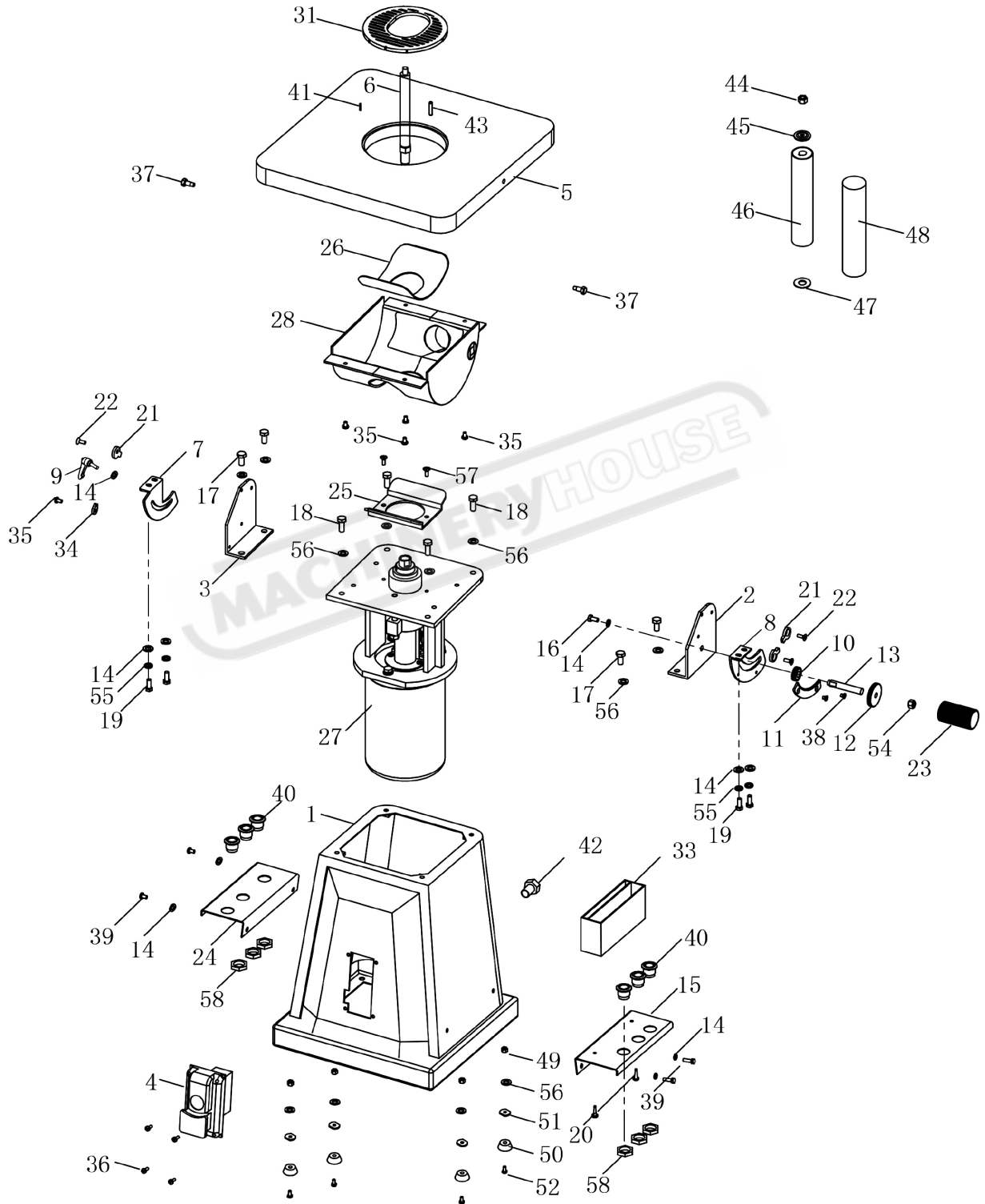

OPERATION MANUAL

SPARE PARTS LIST DIAGRAM A

Key No.	Description	Part No.	Key No.	Description	Part No.
1A	Machine body	P50-300-1A	31A	Table insert	P50-300-31A
2A	Worktable bracket	P50-300-2A	33A	Tool holder for table inserts	P50-300-33A
3A	Worktable bracket	P50-300-3A	34A	Dial indicator	P50-300-34A
4A	Switch	P50-300-4A	35A	Pan head screws M5x8	P50-300-35A
5A	Work table	P50-300-5A	36A	Pan head screws M4x12	P50-300-36A
6A	Connection rod	P50-300-6A	37A	Stepped bolt	P50-300-37A
7A	Rotation bracket of table (Left)	P50-300-7A	38A	Countersunk screws M5x6	P50-300-38A
8A	Rotation bracket of table (Right)	P50-300-8A	39A	Hex bolt M6x12	P50-300-39A
9A	Ratchet level	P50-300-9A	40A	Cone sleeve	P50-300-40A
10A	Small gear	P50-300-10A	41A	Spring pin 2.5x20	P50-300-41A
11A	Rack	P50-300-11A	42A	Cable strain relief M18	P50-300-42A
12A	Locking ring	P50-300-12A	43A	Key 5x50	P50-300-43A
13A	Rotating shaft	P50-300-13A	44A	Left-handed nut M10	P50-300-44A
14A	Washer 6	P50-300-14A	45A	Convex washer	P50-300-45A
15A	Right hand drum frame	P50-300-15A	46A	Rubber sleeve	P50-300-46A
16A	Hex bolt M6x12	P50-300-16A	47A	Washer	P50-300-47A
17A	Hex bolt M8x16	P50-300-17A	48A	Sanding sleeve	P50-300-48A
18A	Hex bolt M8x20	P50-300-18A	49A	Hex nut M8	P50-300-49A
19A	Hex bolt M6x16	P50-300-19A	50A	Rubber washer	P50-300-50A
20A	Tapping screws ST4.0x10	P50-300-20A	51A	Nut washer	P50-300-51A
21A	Eccentric cam	P50-300-21A	52A	Hex bolt M8x25	P50-300-52A
22A	Countersunk screws M6x12	P50-300-22A	54A	Hex nut M10	P50-300-54A
23A	Rotation handle	P50-300-23A	55A	Spring washer 6	P50-300-55A
24A	Tool holder for sanding drums	P50-300-24A	56A	Washer 8	P50-300-56A
25A	Fixed section	P50-300-25A	57A	Pan head screws M6x12	P50-300-57A
26A	Movable section	P50-300-26A	58A	Cone sleeve nut	P50-300-58A
27A	Oscillation assembly	P50-300-27A			
28A	Dust extraction housing/port	P50-300-28A			



OPERATION MANUAL

SPARE PARTS DIAGRAM B

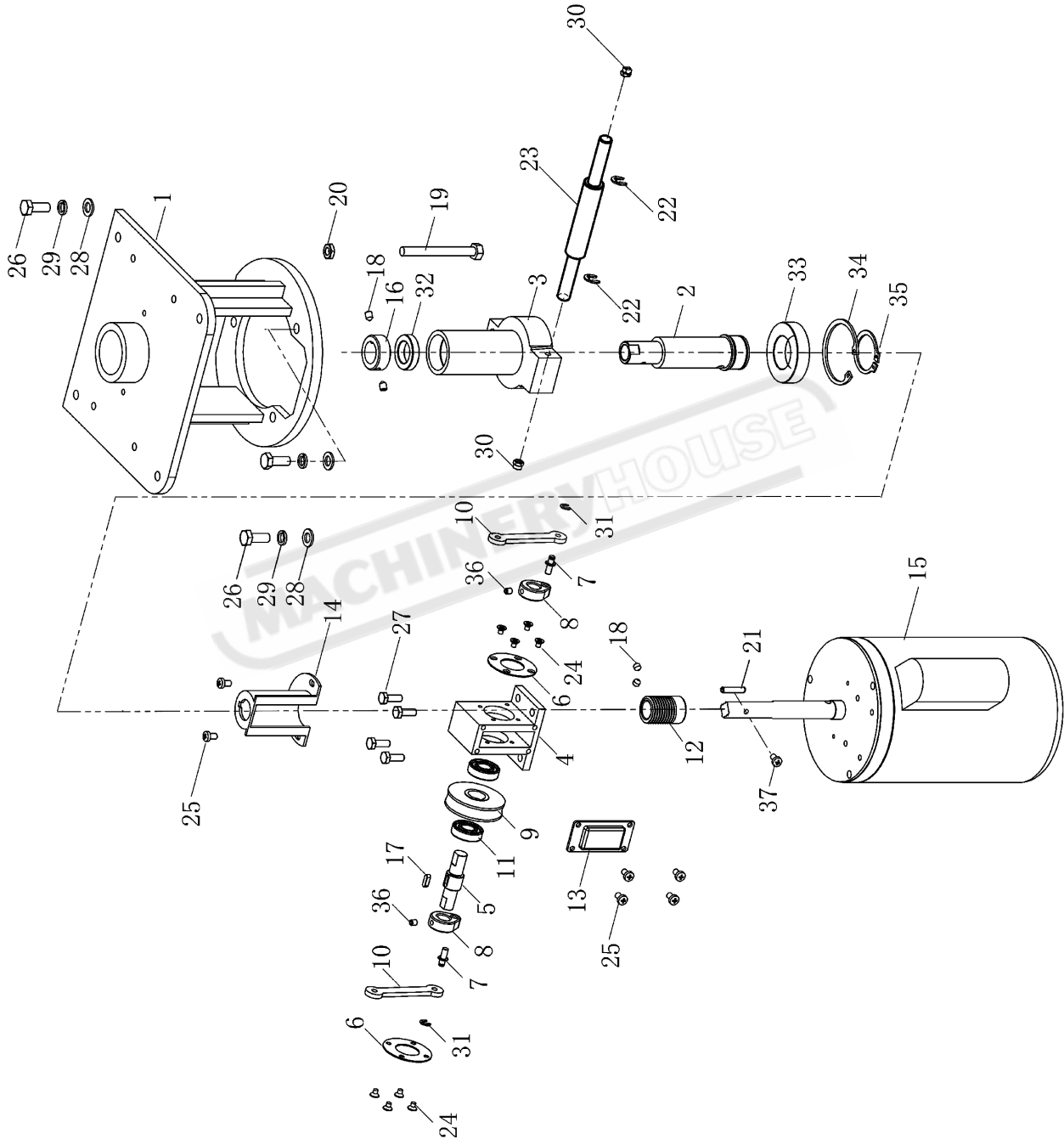

OPERATION MANUAL

SPARE PARTS LIST DIAGRAM B

Key No.	Description	Part No.	Key No.	Description	Part No.
1B	Motor base	P50-300-1B	20B	Hex thin nut M8	P50-300-20B
2B	Spindle bushing & plastic insert	P50-300-2B	21B	Key 5x5x50	P50-300-21B
3B	Guide column	P50-300-3B	22B	E-clip 6mm	P50-300-22B
4B	Worm wheel frame	P50-300-4B	23B	Connecting rod axle	P50-300-23B
5B	Worm wheel spindle	P50-300-5B	24B	Countersunk screw M4x6	P50-300-24B
6B	Bearing gland	P50-300-6B	25B	Pan head screw M5x8	P50-300-25B
7B	Crank axle	P50-300-7B	26B	Hex bolt M8x20	P50-300-26B
8B	Crank	P50-300-8B	27B	Hex bolt M6x16	P50-300-27B
9B	Worm wheel	P50-300-9B	28B	Washer 8	P50-300-28B
10B	Connection rod	P50-300-10B	29B	Spring washer 8	P50-300-29B
11B	Bearing 6001-2RS	P50-300-11B	30B	Self-locking nut M5	P50-300-30B
12B	Worm gear	P50-300-12B	31B	E-clip 4mm	P50-300-31B
13B	Cover, worm wheel frame	P50-300-13B	32B	Bearing 61804	P50-300-32B
14B	Plastic housing for worm gear	P50-300-14B	33B	Bearing 6006	P50-300-33B
15B	Motor	P50-300-15B	34B	Inner circlip 55mm	P50-300-34B
16B	Bearing cover	P50-300-16B	35B	External circlip 30mm	P50-300-35B
17B	Key 4x4x12	P50-300-17B	36B	Socket head screw M5x6	P50-300-36B
18B	Hex set screw with flat M6x6	P50-300-18B	37B	Pan head screw M4x12	P50-300-37B
19B	Hex bolt M8x75	P50-300-19B			

HAFCO WOODMASTER

OPERATION MANUAL

ELECTRICAL

This machine must be grounded. Replacement of the power supply cable should only be done by a qualified electrician. See page 10 for additional electrical information.

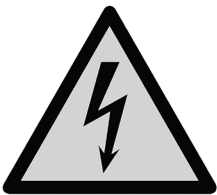
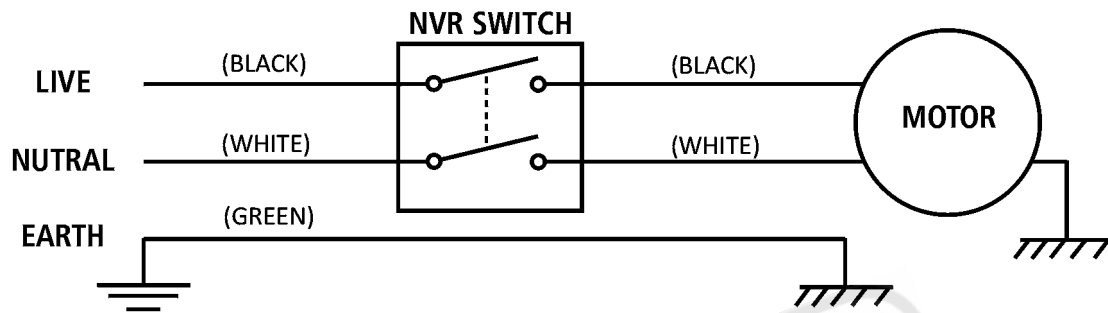

This HAFCO machine is intended for use on a circuit that has a 240 volt electrical supply.
The plug fitted to this machine is SAA approved and should only be changed by a qualified electrician

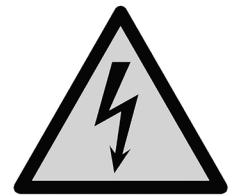



WARNING

General Machinery Safety Instructions

Machinery House
requires you to read this entire Manual before using this machine.

- 1. Read the entire Manual before starting machinery.** Machinery may cause serious injury if not correctly used.
- 2. Always use correct hearing protection when operating machinery.** Machinery noise may cause permanent hearing damage.
- 3. Machinery must never be used when tired, or under the influence of drugs or alcohol.** When running machinery you must be alert at all times.
- 4. Wear correct Clothing.** At all times remove all loose clothing, necklaces, rings, jewelry, etc. Long hair must be contained in a hair net. Non-slip protective footwear must be worn.
- 5. Always wear correct respirators around fumes or dust when operating machinery.** Machinery fumes & dust can cause serious respiratory illness. Dust extractors must be used where applicable.
- 6. Always wear correct safety glasses.** When machining you must use the correct eye protection to prevent injuring your eyes.
- 7. Keep work clean and make sure you have good lighting.** Cluttered and dark shadows may cause accidents.
- 8. Personnel must be properly trained or well supervised when operating machinery.** Make sure you have clear and safe understanding of the machine you are operating.
- 9. Keep children and visitors away.** Make sure children and visitors are at a safe distance for you work area.
- 10. Keep your workshop childproof.** Use padlocks, Turn off master power switches and remove start switch keys.
- 11. Never leave machine unattended.** Turn power off and wait till machine has come to a complete stop before leaving the machine unattended.
- 12. Make a safe working environment.** Do not use machine in a damp, wet area, or where flammable or noxious fumes may exist.
- 13. Disconnect main power before service machine.** Make sure power switch is in the off position before re-connecting.
- 14. Use correct amperage extension cords.** Undersized extension cords overheat and lose power. Replace extension cords if they become damaged.
- 15. Keep machine well maintained.** Keep blades sharp and clean for best and safest performance. Follow instructions when lubricating and changing accessories.
- 16. Keep machine well guarded.** Make sure guards on machine are in place and are all working correctly.
- 17. Do not overreach.** Keep proper footing and balance at all times.
- 18. Secure workpiece.** Use clamps or a vice to hold the workpiece where practical. Keeping the workpiece secure will free up your hand to operate the machine and will protect hand from injury.
- 19. Check machine over before operating.** Check machine for damaged parts, loose bolts, Keys and wrenches left on machine and any other conditions that may effect the machines operation. Repair and replace damaged parts.
- 20. Use recommended accessories.** Refer to instruction manual or ask correct service officer when using accessories. The use of improper accessories may cause the risk of injury.
- 21. Do not force machinery.** Work at the speed and capacity at which the machine or accessory was designed.
- 22. Use correct lifting practice.** Always use the correct lifting methods when using machinery. Incorrect lifting methods can cause serious injury.
- 23. Lock mobile bases.** Make sure any mobile bases are locked before using machine.
- 24. Allergic reactions.** Certain metal shavings and cutting fluids may cause an allergic reaction in people and animals, especially when cutting as the fumes can be inhaled. Make sure you know what type of metal and cutting fluid you will be exposed to and how to avoid contamination.
- 25. Call for help.** If at any time you experience difficulties, stop the machine and call you nearest branch service department for help.



WARNING

Bobbin Sander Safety Instructions

Hare and Forbes Machinery House
requires you to read this entire Manual before using this machine.

- 1. Maintenance.** Make sure the Bobbin Sander is turned off and disconnect from the main power supply and make sure all moving parts have come to a complete stop before any inspection, adjustment or maintenance is carried out.
- 2. Bobbin Sander Condition.** Bobbin Sander must be maintained for a proper working condition. Never operate a Bobbin Sander that has damaged or worn parts. Scheduled routine maintenance should be performed on a scheduled basis.
- 3. Sanding Sleeve Condition.** Never operate a Bobbin Sander with a damaged or badly worn sanding sleeves. Replace if required.
- 4. Sander Rotation.** Be aware of the sander rotation when sanding.
- 5. Hand Hazard.** Keep hands and fingers clear from moving parts. Serious injury can occur if hand or finger tips come in contact with abrasives or moving parts.
- 6. Leaving a Bobbin Sander Unattended.** Always turn the Bobbin Sander off and make sure all moving parts have come to a complete stop before leaving the Bobbin Sander. Do not leave Bobbin Sander running unattended for any reason.
- 7. Avoiding Entanglement.** Remove loose clothing, belts, or jewelry items. Never wear gloves while machine is in operation. Tie up long hair and use the correct hair nets to avoid any entanglement with the Bobbin Sander moving parts.
- 8. Understand the machines controls.** Make sure you understand the use and operation of all controls.
- 9. Power outage.** In the event of a power failure during use of the machine, turn off all switches to avoid possible sudden start up once power is restored.
- 10. Work area hazards.** Keep the area around the Bobbin Sander clean from oil, tools, chips. Pay attention to other persons in the area and know what is going on around the area to ensure unintended accidents.
- 11. Workpiece Handling.** Never hold small workpieces with your fingers during sanding. Always support/feed the workpiece with push stick, table support, vice, or some sort of clamping fixture.
- 12. Hearing protection and hazards.** Always wear hearing protection as noise generated from Bobbin Sander and workpiece vibration can cause permanent hearing loss over time.
- 13. Dust hazards.** Always wear dust mask or respirator and eye protection when sanding. Use a dust collector as well to keep dust to a minimum.
- 14. Feeding material.** Always feed material into the direction of the sander sleeve. Never use excessive force when sanding or serious injury can occur.
- 15. Job Material.** Check material prior to sanding for nails, staple and other objects that make cause any danger when sanding.
- 16. Starting position/speed.** Never turn the Bobbin Sander on when the workpiece is resting on the sander sleeve. Allow sander to reach full speed before sanding.
- 17. Sanding.** Keep workpiece down toward the table whilst sanding. Workpiece may cause serious injury if not held correctly.
- 19. Stopping the Bobbin Sander.** Do not stop or slow the sander with your hand or workpiece. Allow the machine to stop on its own.
- 20. Wood dust may cause allergic reactions.** Make sure you know what type of dust you are exposed to as it may cause you an allergic reaction. Always wear an approved respirator.
- 21. Call for help.** If at any time you experience difficulties, stop the machine and call you nearest branch service department for help.

PLANT SAFETY PROGRAM

NEW MACHINERY HAZARD IDENTIFICATION, ASSESSMENT & CONTROL

Oscillating Spindle Sander

Developed in Co-operation Between A.W.I.S.A and Australia Chamber of Manufactures
This program is based upon the Safe Work Australia, Code of Practice - Managing Risks of Plant in the Workplace (WHSA 2011 No10)

Item No.	Hazard Identification	Hazard Assessment	Risk Control Strategies <small>(Recommended for Purchase / Buyer / User)</small>
A	ENTANGLEMENT	HIGH	Eliminate, avoid loose clothing / Long hair etc.
C	CUTTING, STABBING, PUNCTURING	MEDIUM	Isolate power to machine prior to any checks or maintenance being carried out. Do not adjust or clean machine until the machine has fully stopped.
D	SHEARING	MEDIUM	Stand clear of moving parts on machine.
E	FRICITION	MEDIUM	Make sure all guards are secured shut when machine is on. Keep hands and body clear from bobbin sander spindle.
F	STRIKING	MEDIUM	Wear appropriate protective clothing. Wear safety glasses. Stand clear of moving parts on machine.
H	ELECTRICAL	MEDIUM	Remove all loose objects around moving parts. Ensure belts are in good condition and at correct tension. Always sand on the down stroke of the bobbin sander's rotation.
O	OTHER HAZARDS, NOISE, DUST.	LOW	All electrical enclosures should only be opened with a tool that is not to be kept with the machine. Wear hearing protection as required. Must be connected to a dust extraction.
Plant Safety Program to be read in conjunction with manufactures instructions			



www.machineryhouse.com.au



www.machineryhouse.co.nz

Authorised and signed by:
Safety officer:



Manager:



Revised Date: 12th March 2012